



Dry Compression Rotary Screw Compressors

CSG-2 Series

Flow rate up to 13.5 m³/min, Pressure 4, 6, 8 and 10 bar

Durable and clean-running for sensitive processes

Two-stage dry compression KAESER rotary screw compressors not only impress with their intelligent component layout, but also with their many innovative details – all of course with renowned KAESER quality and KAESER's distinctive, contemporary design. Whether for the semiconductor, food or automotive industries, our two-stage, dry compression compressors tirelessly prove that process-appropriate purity and cost-effectiveness do indeed go hand in hand – even in extreme conditions.

Long-term efficiency

Compressed air simply has to be available where and whenever it is needed. KAESER dry compression rotary screw compressors are therefore built to last and to ensure many years of dependable performance. Comprising tried and tested components that have been developed as a result of KAESER's near century of experience in mechanical engineering, KAESER compressors deliver the durability and compressed air availability to meet even the toughest of demands.

Innovation you can trust

Using all of the advantages that KAESER's advanced Research and Development Centre in Coburg has to offer, KAESER's engineers designed every detail of the two-stage dry compression rotary screw airend with maximum efficiency and performance in mind. Further additional system features include the use of fibre-free pulse dampers and, with water-cooled compressor packages, an integrated heat recovery module.

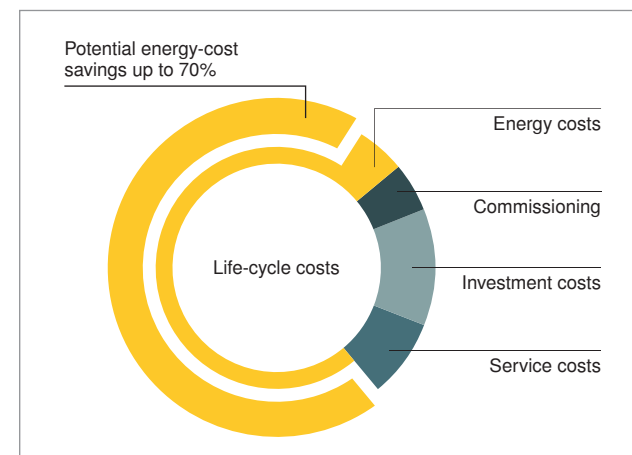

Efficiency as standard

KAESER quality and expertise really count when it comes to those all-important total system costs for asset investments such as compressors or complete compressed air supply systems. Lowest possible compressed air costs and maximum availability can be guaranteed only through a combination of perfect interplay between energy efficiency and service / maintenance, and by viewing the compressed air supply system as a whole.

Service-friendly

These versatile systems were engineered for optimum ease-of-use and servicing right from the outset of the design stage. Fewer wearing parts and the use of premium quality materials ensure reduced maintenance requirement, longer service intervals and extended service life. Excellent component accessibility as a result of generously sized maintenance doors and a swing-out cooler are just some of the features that make servicing so effortless.

Energy-efficiency: the essential requirement

Investment and service costs account for only a small part of a compressor's total life-cycle costs. Since energy accounts for the lion's share of those costs, it's wise to save with KAESER Life-Cycle Management. KAESER has been committed to minimising your energy costs for compressed air production for over 40 years. We also have the bigger picture in clear focus when it comes to service and maintenance, as well as maximum compressed air supply availability.

Contents



CSG-2

Compressor airend	04-05
Drive and control	06-07
Service-friendly design	08-09
Compressors with air-cooling	10-11
Compressors with water-cooling	12-13

Heat recovery

Why recover heat?	14-15
Technical implementation of integrated heat recovery	16-17

Compressed air drying

Process technology – Overview	18-19
Compressors with integrated refrigeration dryer	20-21
Compressors with integrated rotary dryer	22-25

Function diagrams and technical specifications

Compressors with air-cooling	26-27
Compressors with water-cooling	28-29

Equipment and options

Equipment	30
Options	31

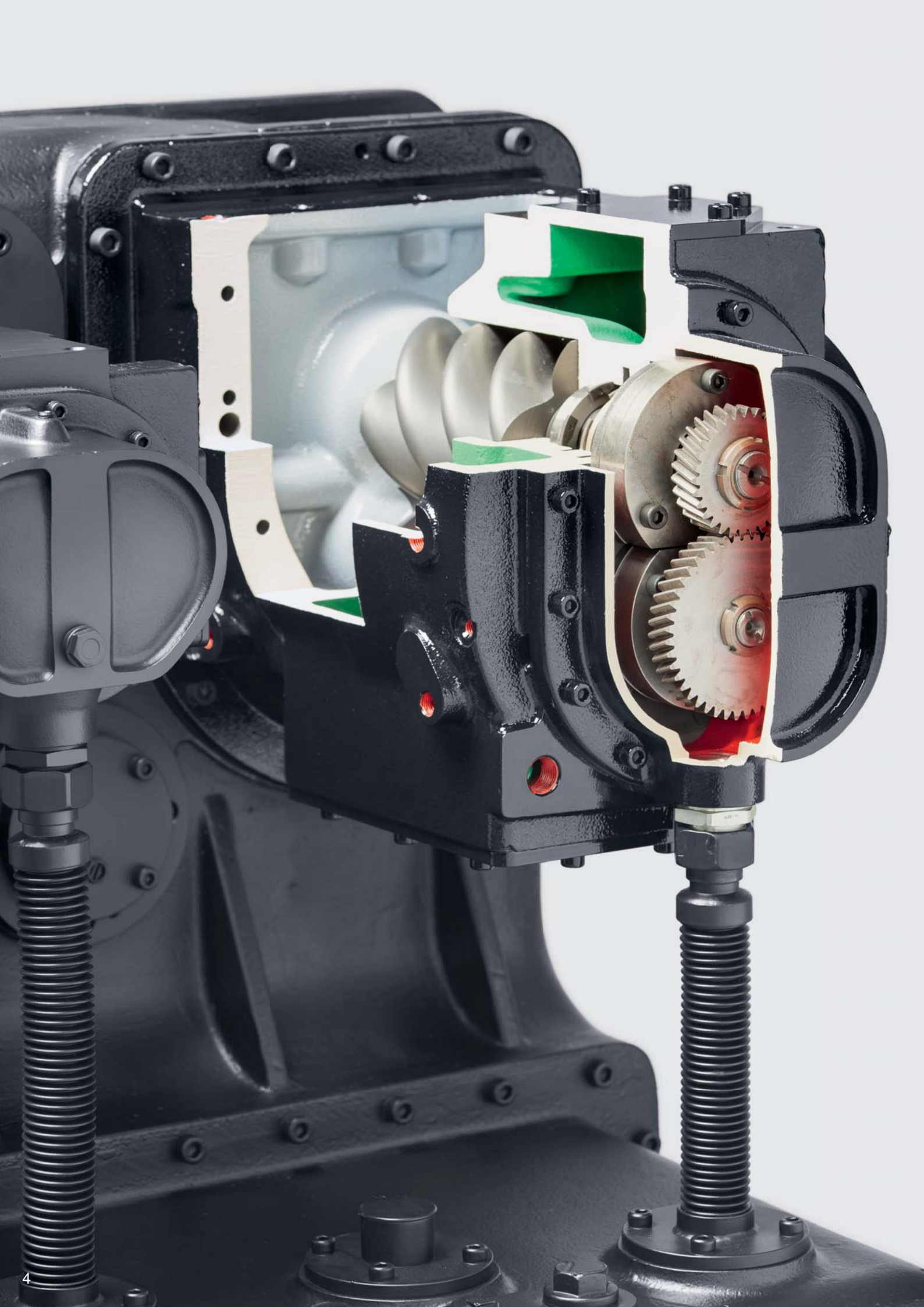

KAESER compressor airends: Precise – durable – efficient



Proven airends

At the heart of every KAESER dry compression rotary screw compressor lies a tried and tested dry-running, two-stage rotary screw airend. Providing optimum performance and dependability, every airend ensures outstanding efficiency throughout its entire service life.



Durable coating

The blasted and bonderised rotors are treated using the special "Ultra Coat" process to produce an innovative and durable coating which is resistant to temperatures of up to 300 °C. Since this cost-reducing coating is highly abrasion-resistant, its sealing and protection performance remains consistent even after years of operation.



Chromium steel rotors

The second compression stage's rotors are made from chromium stainless steel, which eliminates the risk of rotor seizing or jamming caused by corrosion.

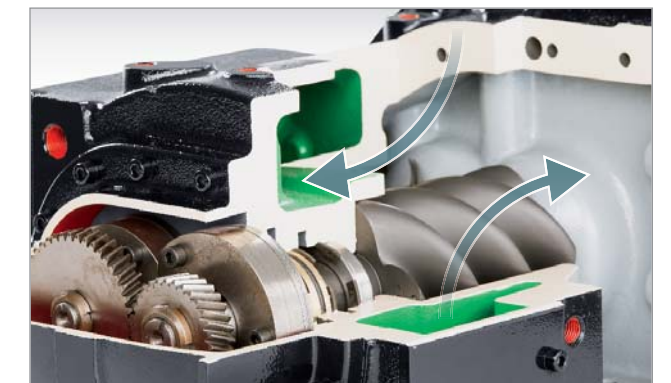

Proven airend cooling

A cooling process known as jacket cooling is used in the low and high pressure compression stages of the airend to ensure optimal heat dissipation, which greatly enhances efficiency.

Efficient drive systems with advanced control



SIGMA CONTROL 2: optimum efficiency

The internal SIGMA CONTROL 2 controller always ensures efficient control and monitoring of compressor operation. The large display and RFID reader provide easy communication and maximum security. Variable interfaces enable seamless networking capability, whilst the SD card slot makes updates quick and easy.



The future, today: IE4 motors

KAESER is currently the only compressed air systems provider to equip its compressors with super premium efficiency IE4 motors as standard, thereby delivering maximum performance and energy efficiency.

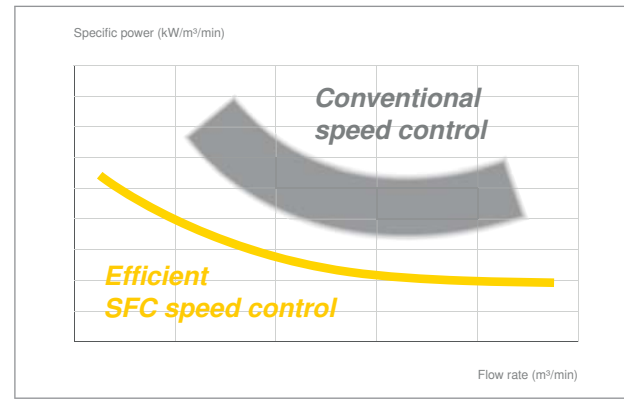

Optimised specific power

The moderate maximum speed, the extra dense screw profile and the near-constant specific power across the wide variable speed control range all combine to achieve significant energy savings throughout the entire operating curve.



SIGMA AIR MANAGER 4.0

This advanced master control system can co-ordinate operation of 4, 8 or 16 rotary screw compressors with maximum energy efficiency and also enables seamless documentation of all operational parameters.



Service...

...virtually maintenance-free



(1) Hydraulic inlet valve

The hydraulically operated inlet valves in KAESER dry compression rotary screw compressors are unaffected by contamination and condensate. This enhances their reliability and ease of maintenance compared to pneumatic valves.

(2) Fibre-free pulse dampers

KAESER's new fibre-free pulse dampers keep pressure losses to an absolute minimum, help maintain consistent air quality and minimise unwanted vibration. In addition, their fibre-free design reliably eliminates the possibility of compressed air contamination.

...excellent accessibility

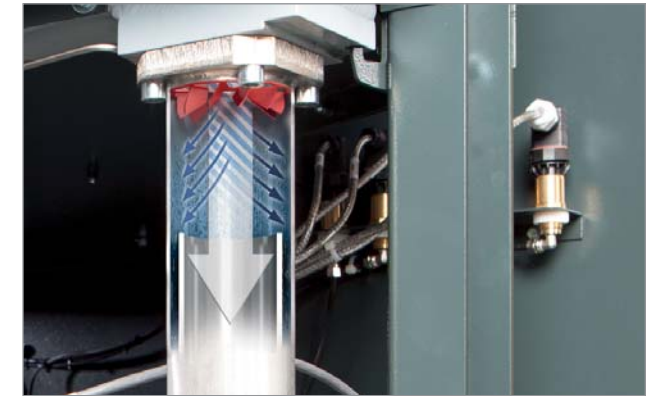

(3) Easy-access coupling

The electric motor directly drives the airend via a maintenance-free coupling, which virtually eliminates transmission losses. As there is no need for complicated disassembly work, the easy-access coupling can be exchanged quickly and easily.

(4) High efficiency condensate separator

Thanks to its flow-optimised design, the newly developed condensate separator reliably separates the condensate downstream from the air coolers – with minimal pressure loss.



Image: CSG 120-2 RD SFC W

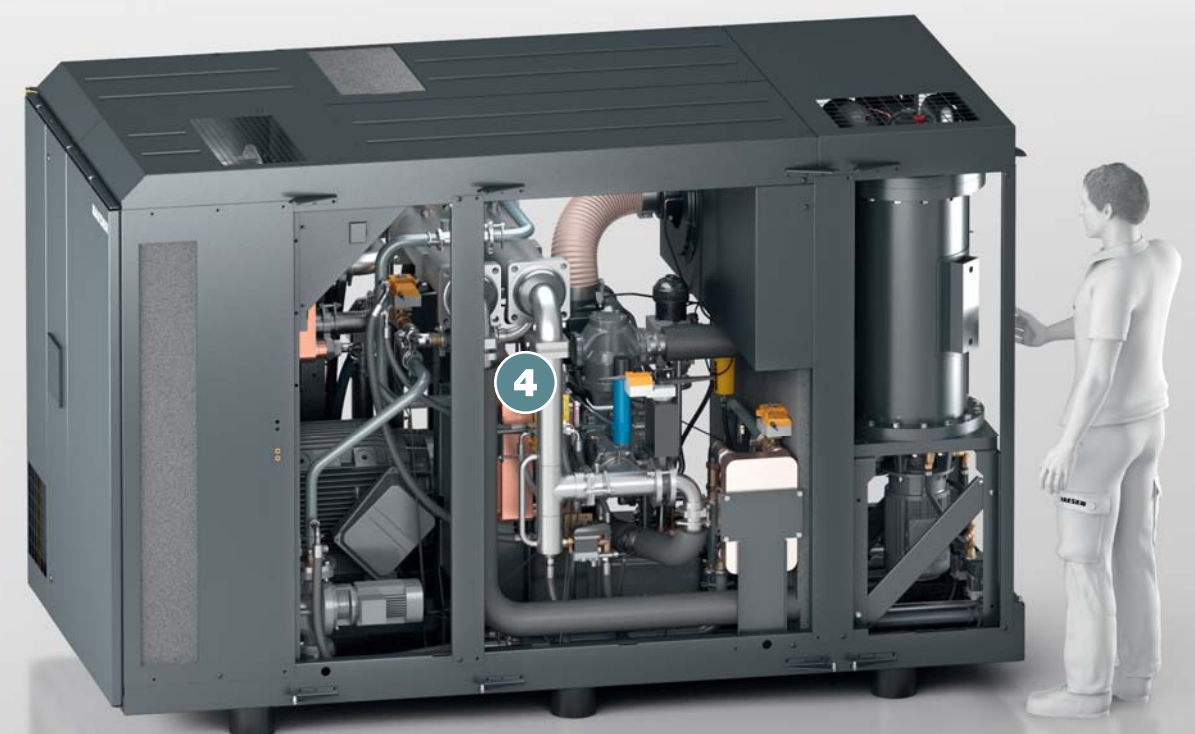
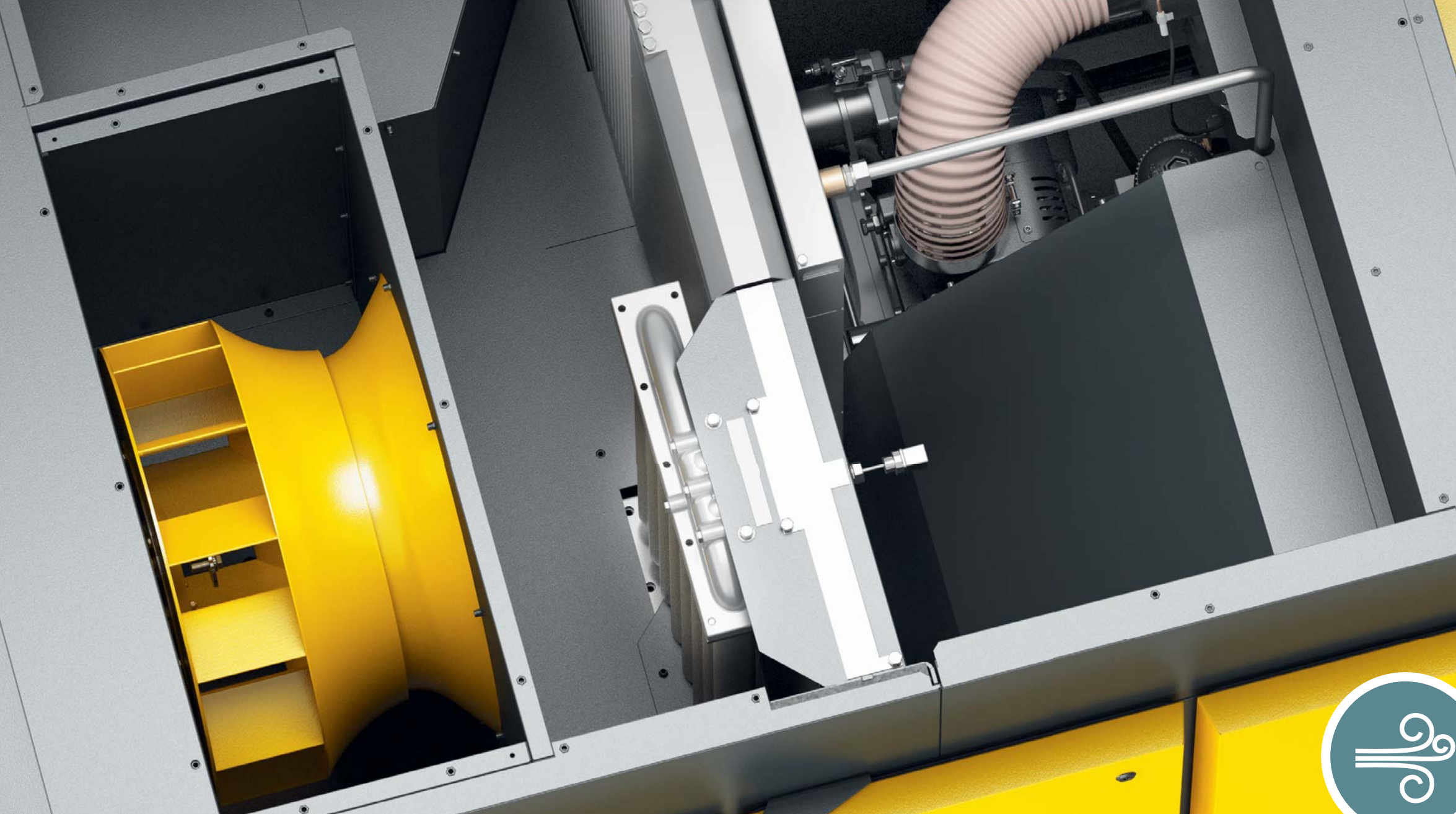

Image: CSG 120-2 RD SFC W



Air-cooling

Dependable performance – even under extreme conditions

The benefits:

- Cooling-water infrastructure is no longer required.
- Meticulously designed machines with logical component layout make maintenance and service work quick and easy thereby ensuring further savings.
- The heated cooling air can be easily re-used for space-heating purposes.

◀ Image: CSG 120-2 A



Cleaning made simple

Thorough cleaning of the air aftercoolers doesn't require the use of a crane – they can be simple swung out by a service technician. Cleaning can then be performed quickly and easily next to the machine without the risk of contaminating the compressor unit's interior.



Operation in ambient temperatures to +45 °C as standard

Air-cooled CSG machines operate dependably in ambient temperatures up to +45 °C thanks to their durable and energy-efficient radial fan.



Outstanding durability through pre-cooling

Highly effective pre-cooling with a stainless steel tube cooler on the high pressure side ensures outstanding air cooler durability. Furthermore, this durable cooler combination also delivers comparably low compressed air discharge temperatures.



Energy-saving standstill fan

When the large radial fan in air-cooled CSG units is switched off as part of the transition to standby mode, the energy-saving, temperature-controlled standstill fan reliably removes remaining heat in the compressor.

Water-cooling

Compact energy-savers

The benefits:

- Exceptionally low compressed air discharge temperature thanks to high quality separate air cooler.
- Load-dependent cooling-water control for optimum compressor cooling and simultaneous efficient use of cooling-water.
- Compact and low design.

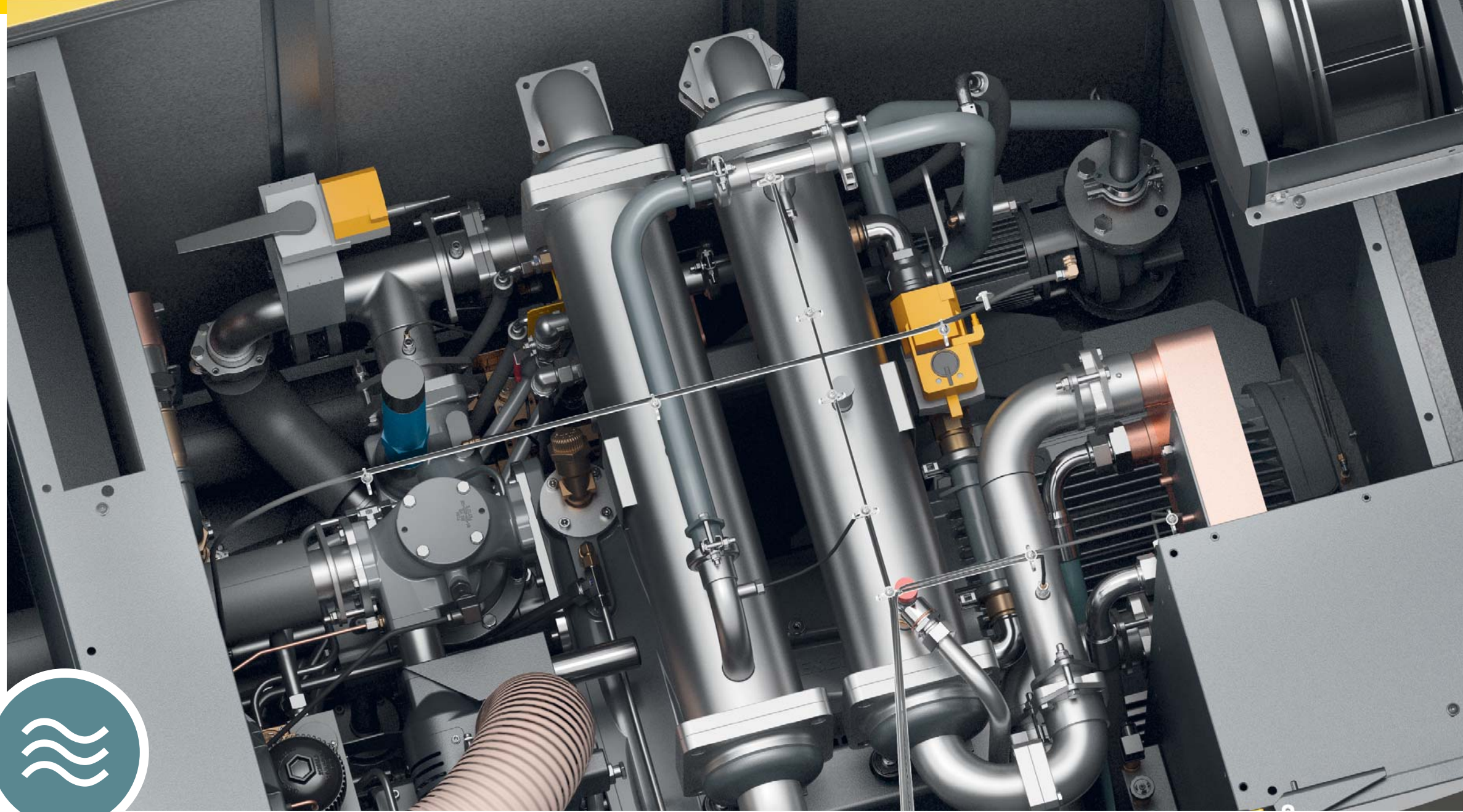

Image: CSG 120-2 RD W SFC ▶



Parallel heat exchanger

Both the low and high pressure stages of water-cooled KAESER dry compression rotary screw compressors are equipped with their own dedicated parallel heat exchanger for enhanced heat transfer. This optimised cooling consequently improves specific power performance.



Optimised water cooler

Water-cooled CSG compressors feature highly efficient air/water heat exchangers. CuNi10Fe cooling pipes with internal star lamella fins provide optimum heat transfer and lowest possible compressed air discharge temperatures with minimal pressure loss.

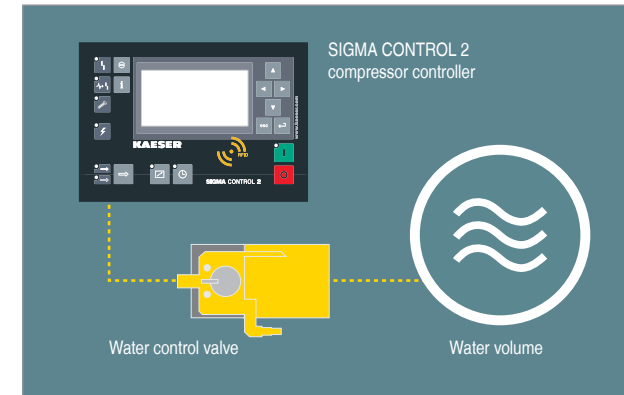

Clever control

Water-cooled CSG-2 compressors feature sealed water control valves that are actuated via the advanced SIGMA CONTROL 2 compressor controller which precisely adjusts water volume to meet actual load requirement.



Permanent adjustment

The important but time-consuming task of performing hydraulic adjustment of both air coolers is carried out permanently and automatically during commissioning and when the machine is in operation. Cooling performance is therefore optimally matched to the operating conditions.



Amortisation period < 1 year

Why recover heat?

The question should in fact be: Why not?

You reduce your company's primary energy consumption and improve the CO₂ balance.

Compressors with air-cooling

Users need to develop clever ideas regarding the use of warm compressor exhaust air. KAESER has the expertise to help you with everything you need to know and will be by your side every step of the way.

Compressors with water-cooling

Using the compact heat recovery module integrated into the compressor, generation of hot water for production or auxiliary heating purposes couldn't be simpler. Cost- and space-intensive external infrastructure is therefore not necessary with KAESER solutions and the amortisation period of the heat recovery module is usually less than a year (see example calculation below).

Example amortisation calculation	
Inlet temperature	20 °C
Relative humidity	30 %
Cooling water inlet (primary)	20 °C
Cooling water outlet (primary)	80 °C
Compressor power consumption CSG-130-2 10 bar (g)	96.8 kW
Heat recovery potential based on total power consumption	87 %
Recoverable heat capacity	84.2 kW
Annual operating hours	6,000 hrs
Kilowatt hours per year	505,296 kWh
Fuel costs	0.02 €/kWh
Annual fuel cost savings	€ 10,105
Amortisation period	< 1 year

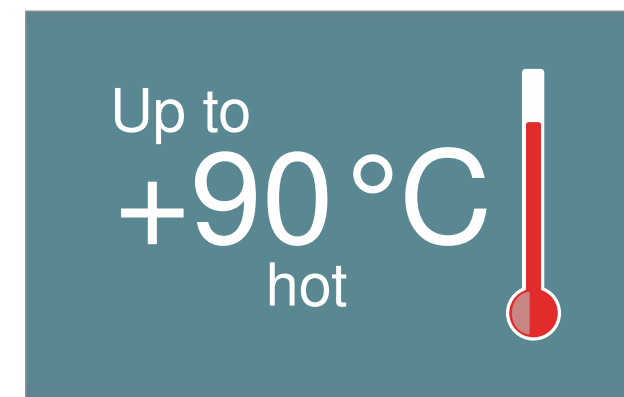

Process, heating and service water

Compressor exhaust heat can be used to produce hot water with temperatures up to +90 °C, which can then be used for a wide range of applications.



Space heating with warm exhaust air

Heating made easy: thanks to radial fans with high residual thrust, the reusable (warm) air from air-cooled CSG-2 systems can be easily ducted away to spaces that require heating – and usually without the need for additional fans.

Technical implementation of integrated heat recovery

Water-cooled CSG version with heat recovery

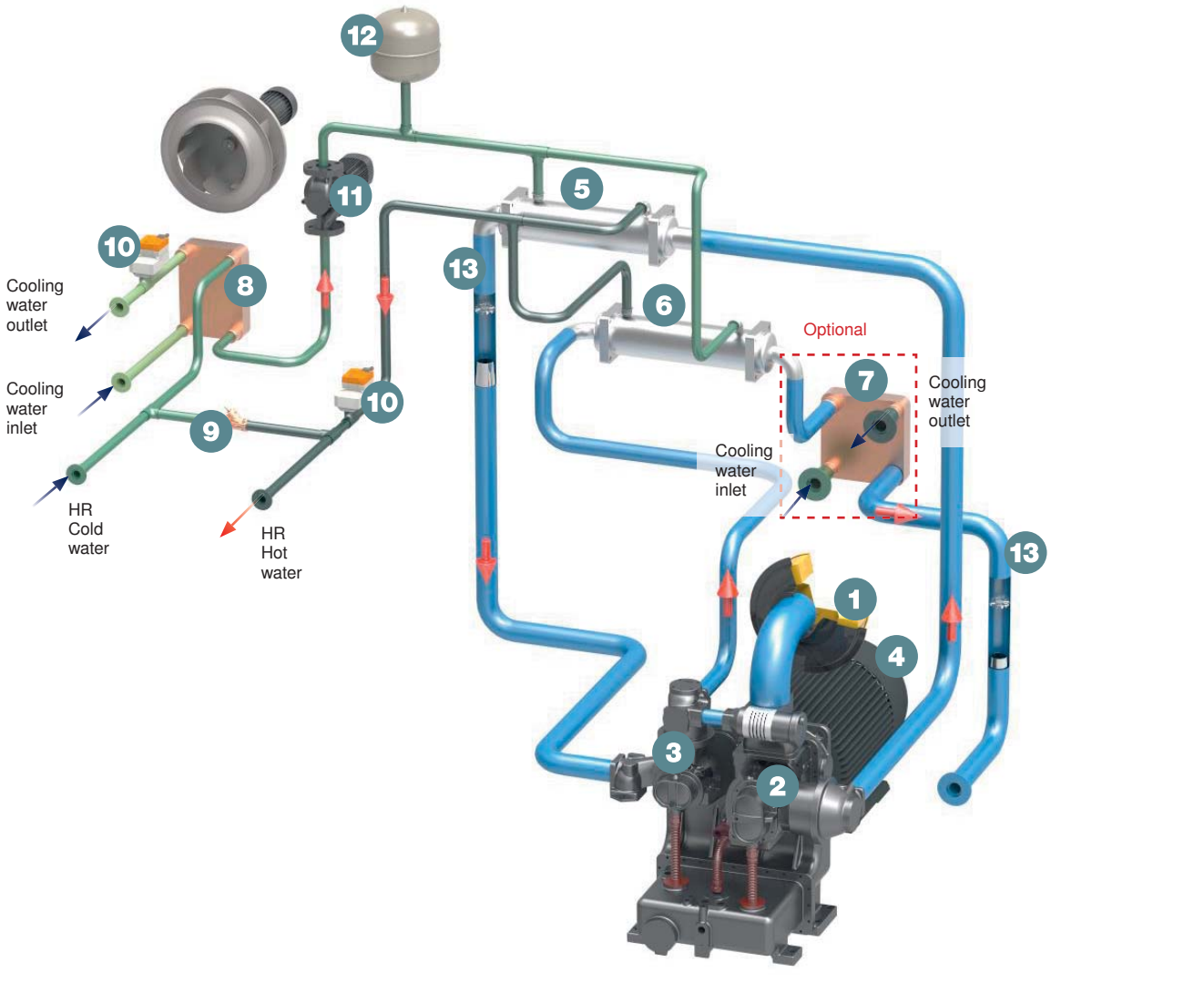

- (1) Intake filter
- (2) Low pressure stage (Stage 1)
- (3) High pressure stage (Stage 2)
- (4) Drive motor
- (5) Air cooler downstream from Stage 1 (air/water)
- (6) Air cooler downstream from Stage 2 (air/water)
- (7) Optional additional heat exchanger (air/water)
→ Version as plate heat exchanger
- (8) Heat exchanger (water/water)
- (9) Check valve
- (10) Water control valve
(actuated by SIGMA CONTROL)
- (11) Pump
- (12) Expansion tank
- (13) Condensate separator
- (14) Integrated i.HOC rotary dryer

In two-stage dry compression rotary screw compressors, some 90 % of the usable heat is processed through the two air coolers (5) and (6). KAESER therefore uses separate, high-quality heat exchangers developed specially to meet heat recovery requirements. The remaining 10 % of usable heat is processed through the oil cooler and in the jacket cooling system of the compression stages.



Versions with rotary dryer

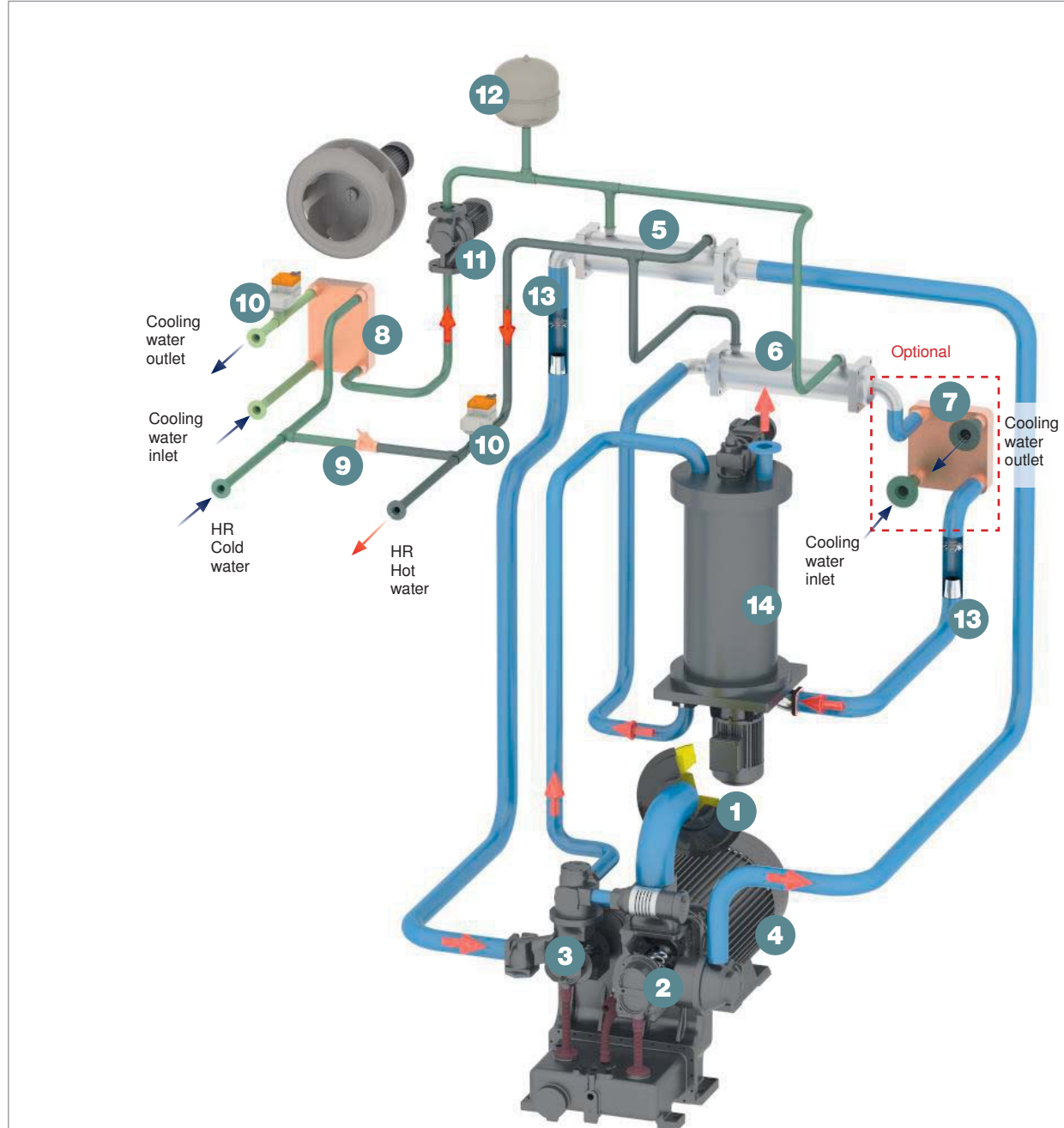

Compressed air drying process – Overview

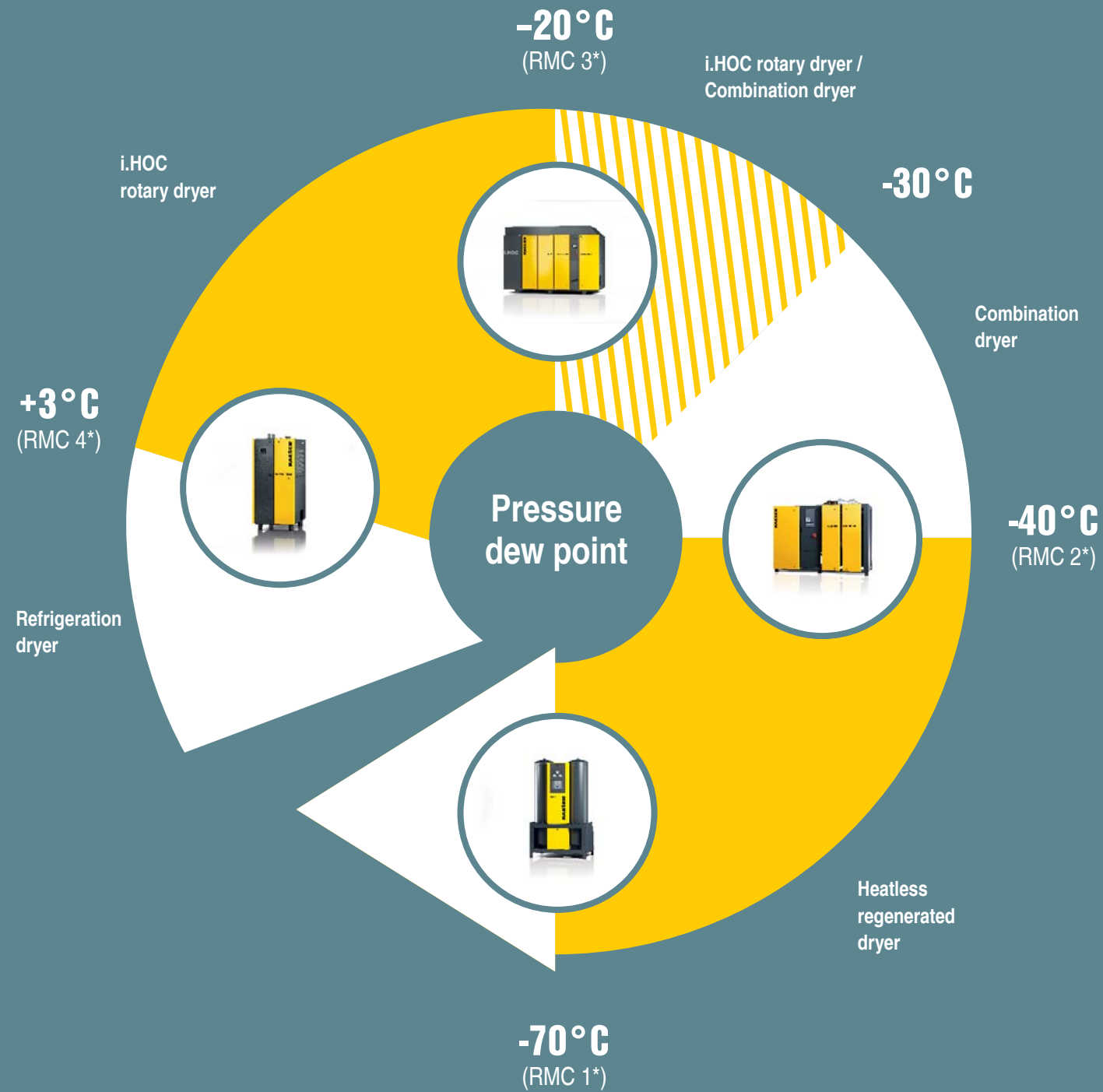

*) RMC = Residual Moisture Class as per ISO 8573-1(2010)

Precision analysis essential

The required dew point plays a significant role in determining the drying process, as well as the investment, service and energy costs associated with compressed air drying. It is therefore highly recommended to carry out a detailed system analysis. Unnecessarily high compressed air volume creates additional costs, which is something that we will gladly help you avoid!



Refrigeration dryer

Even for dry-running rotary screw compressors, refrigeration dryers are the go-to choice for delivering best possible energy efficiency and favourable investment costs when requiring pressure dew points to **+3 °C**. Pressure dew points below **+3 °C** are provided by desiccant dryers.



i.HOC rotary dryer

The optional i.HOC rotary dryer for integration in the rotary screw compressor can reliably and efficiently achieve pressure dew points as low as **-30 °C**. The hot compressed air from the second compression stage is used to regenerate the desiccant.



Combination dryer

HYBRITEC dryers combine the energy-saving operation of modern refrigeration dryers with the ultra-low pressure dew points of desiccant dryers. HYBRITEC dryers achieve pressure dew points as low as **-40 °C** with exceptional efficiency.



Heatless regenerated dryer

KAESER's DC series heatless regenerated desiccant dryers achieve pressure dew points to **-70 °C**, even under extreme operating conditions.

Integrated refrigeration drying

KAESER refrigeration dryers ensure perfect drying of compressed air for the intended application and all flow rates. Since they are high-quality industrial machines, you'll be providing reliable protection against condensate damage for your systems and processes, even under the harshest of conditions.



Energy-saving drying

Integrated design, together with the generously-dimensioned aluminium block heat exchanger, helps ensure minimal pressure loss of less than 0.1 bar. The energy-saving scroll refrigeration compressor helps achieve additional compressed air energy savings.



Excellent accessibility

All refrigeration dryer components are perfectly accessible via the service door on the front of the unit. Dryer service and maintenance work is therefore a breeze.



Image: CSG 120-2 T SFC A



Image: CSG 120-2 RD SFC, person shown 1.80 m tall

i.HOC

Dependable pressure dew point through innovative process engineering

The patented i.HOC rotary dryer from KAESER uses up to 100 % of the compression heat! Thanks to this full-flow regeneration method, these dryers deliver reliable pressure dew points to an ambient temperature of +45 °C – completely without electrical heating or additional cooling of the regeneration air. Air- and water-cooled versions are available.

The benefits:

- Dependable sub-zero pressure dew points even with high ambient or coolant temperatures.
- Pressure dew point stability even at lowest compressor load – completely without the need for a partial load compensator.
- Available with pressure dew point control as required!
- Highly effective drying and heat recovery with water-cooled compressors.

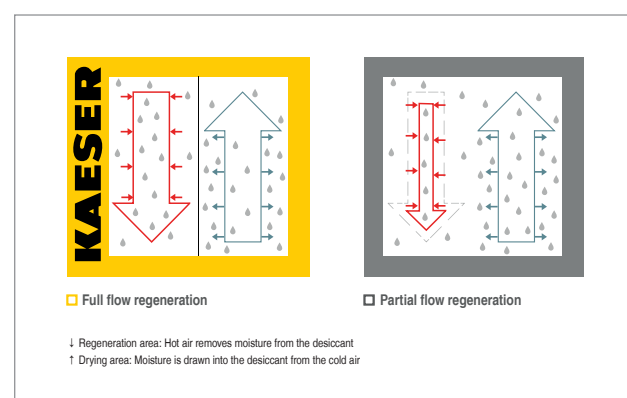

Full-flow regeneration in detail

The i.HOC (Integrated Heat of Compression Dryer) system uses 100% of the heat of compression from the second compression stage for drying purposes (full-flow regeneration). This heat, which is produced in any case, is therefore effectively available at zero cost.

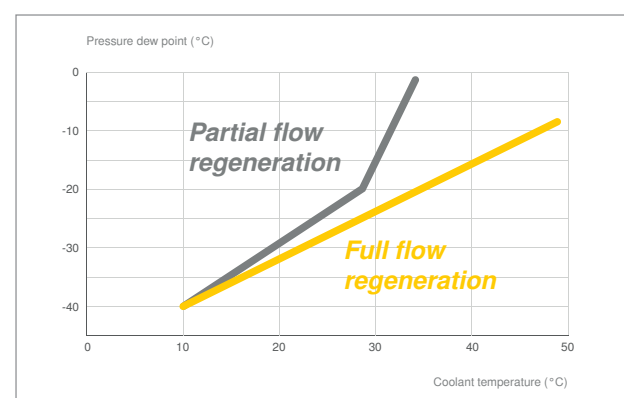

Drying even near the limit

The advantages of full flow regeneration become obvious, especially with increased coolant temperatures. KAESER rotation dryers achieve outstanding drying results even without additional electric heating of the regeneration air.

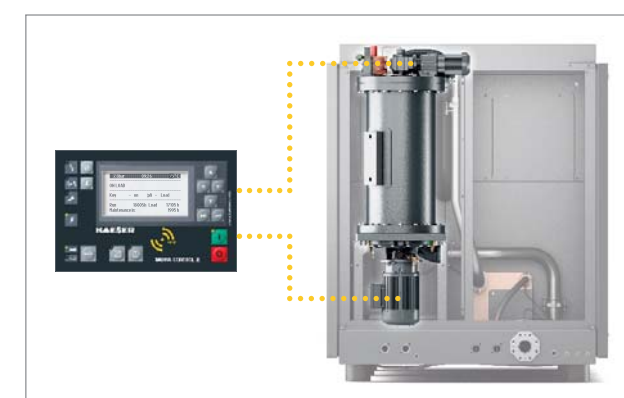

Perfect performance

The i.HOC rotary dryer's intelligent control ensures dew point stability even with fluctuating flow rates and at compressor partial load. When commissioned, the target pressure dew point is reached after just one rotation of the drum.

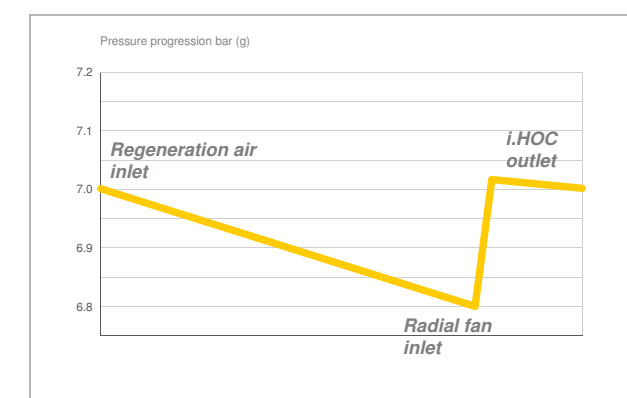

Pressure loss? On the contrary!

The radial fan in the floor of the rotary dryer equalises drying process pressure losses as required, thereby guaranteeing maximum pressure dew point stability and quality – the pressure at the i.HOC dryer outlet is higher even than at the inlet!

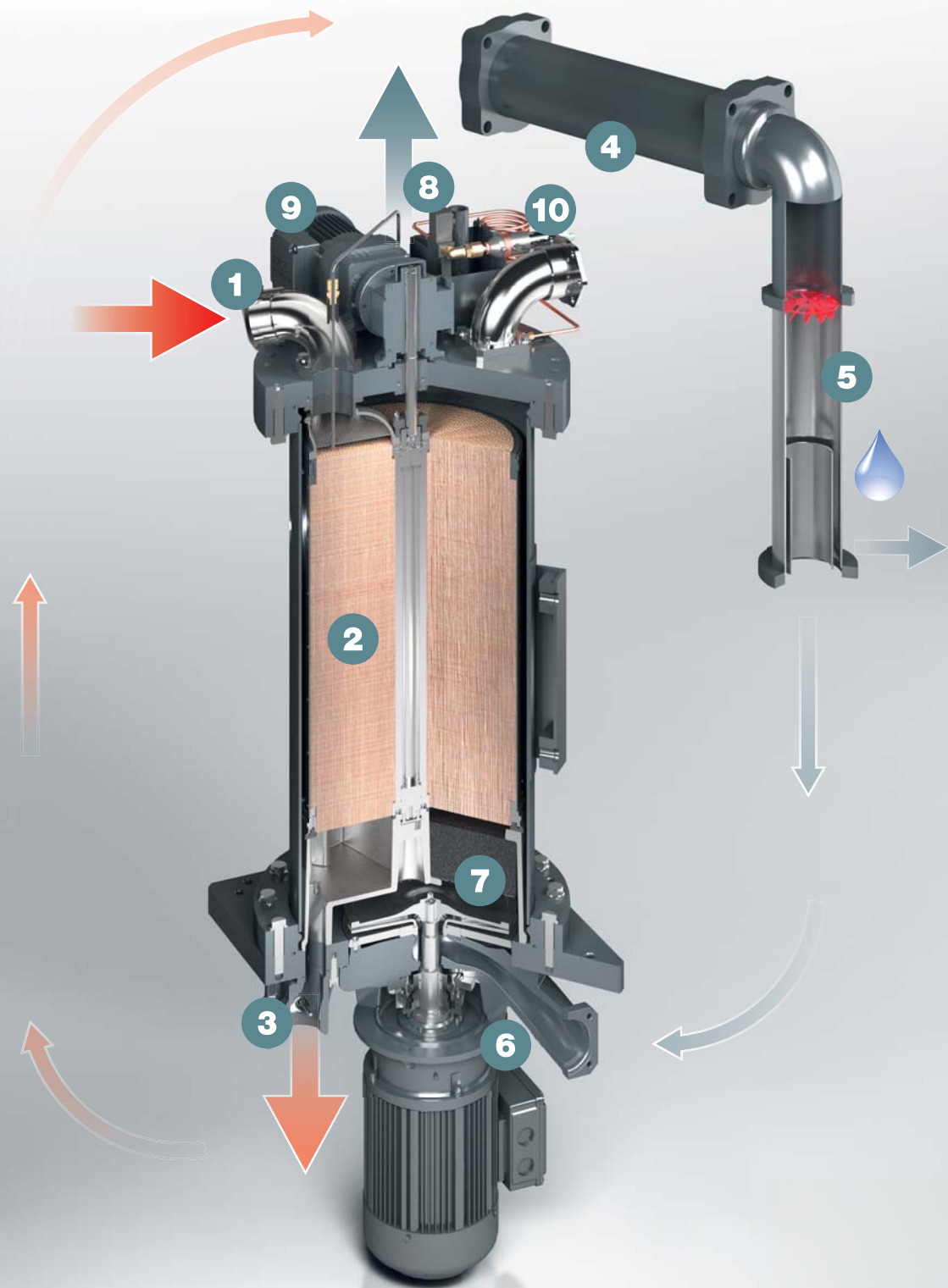

Image: RD 130 rotary dryer

- | | |
|-----------------------------|---|
| (1) Regeneration air inlet | (6) Radial fan |
| (2) Drum | (7) Demister |
| (3) Regeneration air outlet | (8) i.HOC rotation dryer outlet |
| (4) Heat exchanger stage 2 | (9) Drum motor |
| (5) Condensate separator | (10) Pressure dew point sensor (optional) |

i.HOC

Precision for efficiency and low pressure dew points



Precision drum

The silica gel desiccant is bedded in a precision manufactured drum with exceptionally high run-out qualities. Incorrect flows within the dryer and resulting pressure dew point fluctuations are therefore reliably prevented.



Variable speed drum motor

The speed of the drum is automatically adjusted according to actual compressor performance in order to regenerate the desiccant as effectively as possible. This is the key to ensuring consistently low pressure dew points.



Durable and efficient

Thanks to CFD optimisation, the flow-optimised radial fan installed in the base of the dryer efficiently compensates the pressure losses in the i.HOC cooling path.

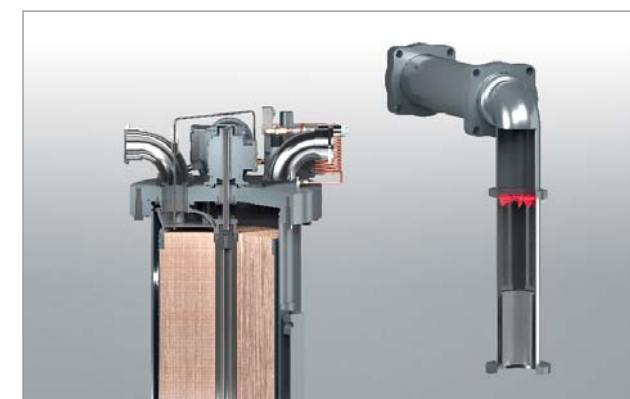

External condensate separation

The i.HOC system uses a highly efficient condensate separator downstream from the heat exchanger in the second compression stage in order to separate the condensate that occurs during the regeneration process **outside of the dryer**. This protects the drum from potentially damaging water droplets.

Technical expertise

Air-cooled CSG packages

Standard versions



How they work



Versions with rotary dryer



How they work



Versions with dryer



How they work



- (1) Inlet filter
- (2) Low pressure stage
- (3) High pressure stage
- (4) Air cooler downstream from Stage 1 (air/water)
- (5) Air cooler downstream from Stage 2 (air/water)
- (6) Oil cooler
- (7) Standstill fan
- (8) i.HOC rotary dryer, integrated
- (9) Refrigeration dryer, integrated

Rated motor power	Operating pressure	Standard					SFC				
		Model	Flow rate complete unit at max. working pressure ¹⁾	Pressure dew point ²⁾	Sound pressure level ²⁾	Mass	Model	Flow rate complete unit at max. working pressure ¹⁾	Pressure dew point ²⁾	Sound pressure level ²⁾	Mass
kW	bar		m ³ /min	°C	dB(A)	kg		m ³ /min	°C	dB(A)	kg

Standard versions

37	4 6 8 10	CSG 55-2	Upon request Upon request 5.40 -	-	71	2270	-	-	-	-	-
45	4 6 8 10	CSG 70-2	8.92 7.77 6.65 Upon request	-	71	2310	-	-	-	-	-
55	4 6 8 10	CSG 90-2	10.52 9.62 8.80 7.67	-	72	2375	CSG 90-2 SFC	3.32 - 10.62 3.23 - 9.45 3.47 - 8.20 Upon request	-	72	2435
75	4 6 8 10	CSG 120-2	12.97 12.92 12.00 10.43	-	73	2515	CSG 120-2 SFC	3.94 - 13.23 4.51 - 12.31 5.08 - 11.20 4.81 - 10.00	-	73	2575
90	4 6 8 10	CSG 130-2	- 12.88 12.85	-	74	2640	CSG 130-2 SFC	4.23 - 13.35 4.64 - 13.26 5.05 - 13.17 5.47 - 12.57	-	74	2700

Versions with rotary dryer

37	6 8 10	CSG 55-2	Upon request 5.40 -	Upon request -36 -	71	2985	-	-	-	-	-
45	6 8 10	CSG 70-2	7.77 6.65 Upon request	-28 -35 Upon request	71	3025	-	-	-	-	-
55	6 8 10	CSG 90-2	9.62 8.80 7.67	-25 -33 -36	72	3090	CSG 90-2 SFC	3.23 - 9.45 3.47 - 8.20 Upon request	-25 -33 Upon request	72	3150
75	6 8 10	CSG 120-2	12.92 12.00 10.43	-19 -29 -34	73	3230	CSG 120-2 SFC	4.51 - 12.31 5.08 - 11.20 4.81 - 10.00	-21 -30 -34	73	3290
90	6 8 10	CSG 130-2	- 12.88 12.85	- -28 -32	74	3355	CSG 130-2 SFC	4.64 - 13.26 5.05 - 13.17 5.47 - 12.57	-20 -28 -32	74	3415

Versions with dryer

37	4 6 8 10	CSG 55-2	Upon request Upon request 5.40 -	3	71	2520	-	-	-	-	-
45	4 6 8 10	CSG 70-2	8.92 7.77 6.65 Upon request	3	71	2560	-	-	-	-	-
55	4 6 8 10	CSG 90-2	10.52 9.62 8.80 7.67	3	72	2625	CSG 90-2 SFC	3.32 - 10.62 3.23 - 9.45 3.47 - 8.20 Upon request	3	72	2685
75	4 6 8 10	CSG 120-2	12.97 12.92 12.00 10.43	3	73	2765	CSG 120-2 SFC	3.94 - 13.23 4.51 - 12.31 5.08 - 11.20 4.81 - 10.00	3	73	2825
90	4 6 8 10	CSG 130-2	- 12.88 12.85	3	74	2890	CSG 130-2 SFC	4.23 - 13.35 4.64 - 13.26 5.05 - 13.17 5.47 - 12.57	3	74	2950

¹⁾ Flow rate in accordance according to ISO 1217:2009, Annex C: absolute input pressure 1 bar(a); cooling and air input temperature 20 °C
²⁾ Sound pressure level according to ISO 2151 and the basic standard ISO 9614-2, tolerance: ± 3 dB(A), measured at maximum pressure and maximum speed
³⁾ Pressure dew point at inlet valve 1 bar(a); cooling and air inlet temperature 20 °C; relative humidity 60%, cooling water outlet temperature 30 °C

Specifications subject to change without notice

Technical expertise

Water-cooled CSG packages

Standard versions

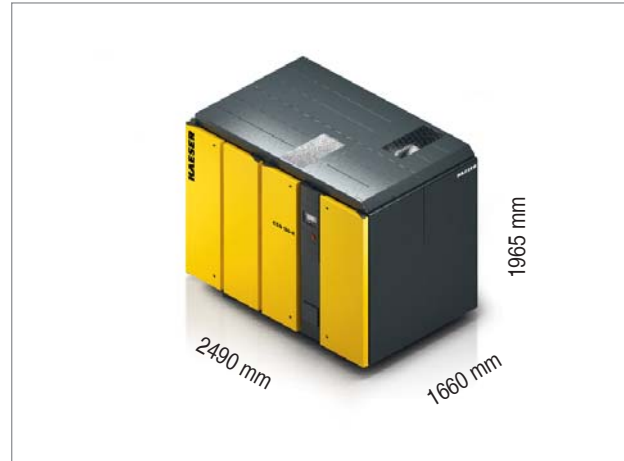

How they work

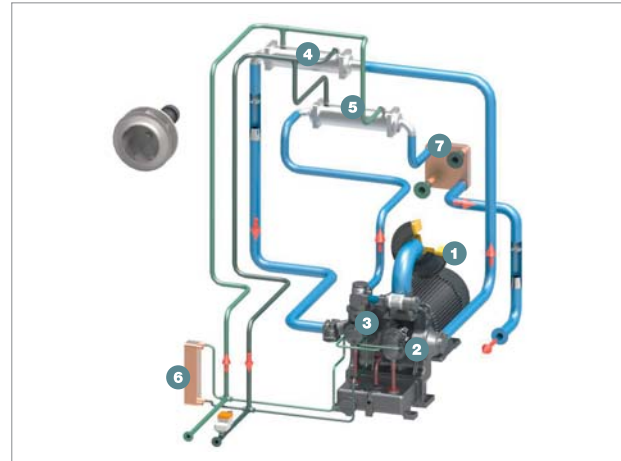

Versions with rotary dryer



How they work

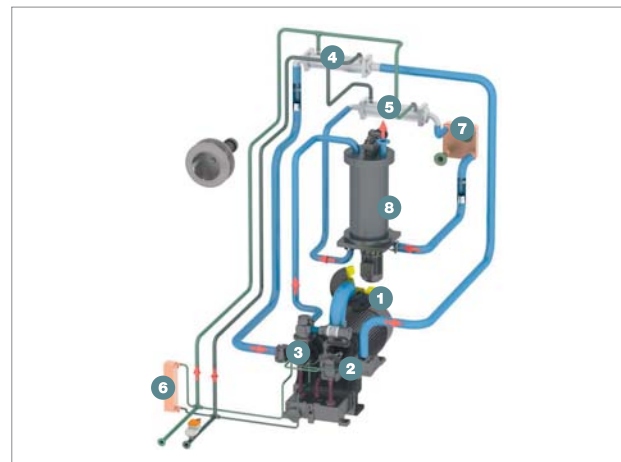

Versions with dryer



How they work



- (1) Inlet filter
- (2) Low pressure stage
- (3) High pressure stage
- (4) Air cooler downstream from Stage 1 (air/water)
- (5) Air cooler downstream from Stage 2 (air/water)
- (6) Oil cooler
- (7) Auxiliary heat exchanger downstream from Stage 2 air cooler (optional)
- (8) i.HOC rotary dryer, integrated
- (9) Refrigeration dryer

Rated motor power	Operating pressure	Standard					SFC				
		Model	Flow rate complete unit at max. working pressure ¹⁾	Pressure dew point ²⁾	Sound pressure level ²⁾	Mass	Model	Flow rate complete unit at max. working pressure ¹⁾	Pressure dew point ²⁾	Sound pressure level ²⁾	Mass
kW	bar		m ³ /min	°C	dB(A)	kg		m ³ /min	°C	dB(A)	kg

Standard versions

37	4 6 8 10	CSG 55-2	Upon request Upon request 5.57 -	-	64	2270	-	-	-	-	-
45	4 6 8 10	CSG 70-2	9.05 7.92 6.82 Upon request	-	64	2310	-	-	-	-	-
55	4 6 8 10	CSG 90-2	10.67 9.78 8.97 7.83	-	65	2375	CSG 90-2 SFC	3.49 - 10.85 3.62 - 9.77 3.84 - 8.58 3.96 - 7.57	-	65	2435
75	4 6 8 10	CSG 120-2	13.10 13.07 12.15 10.58	-	66	2515	CSG 120-2 SFC	4.20 - 13.27 4.18 - 12.61 4.21 - 11.56 4.23 - 10.52	-	66	2575
90	4 6 8 10	CSG 130-2	- 13.03 13.00	-	68	2640	CSG 130-2 SFC	4.40 - 13.48 4.33 - 13.44 4.26 - 13.40 4.20 - 13.02	-	68	2700

Versions with rotary dryer

37	6 8 10	CSG 55-2	Upon request 5.57 -	Upon request -33 -	64	2985	-	-	-	-	-
45	6 8 10	CSG 70-2	7.92 6.82 Upon request	-25 -32 Upon request	64	3025	-	-	-	-	-
55	6 8 10	CSG 90-2	9.78 8.97 7.83	-23 -31 -35	65	3090	CSG 90-2 SFC	3.62 - 9.77 3.84 - 8.58 3.96 - 7.57	-23 -31 -35	65	3150
75	6 8 10	CSG 120-2	13.07 12.15 10.58	-20 -29 -34	66	3230	CSG 120-2 SFC	4.18 - 12.61 4.21 - 11.56 4.23 - 10.52	-21 -29 -34	66	3290
90	6 8 10	CSG 130-2	- 13.03 13.00	- -28 -33	68	3355	CSG 130-2 SFC	4.33 - 13.44 4.26 - 13.40 4.20 - 13.02	-20 -28 -33	68	3415

Versions with dryer

37	4 6 8 10	CSG 55-2	Upon request Upon request 5.57 -	3	64	2520	-	-	-	-	-
45	4 6 8 10	CSG 70-2	9.05 7.92 6.82 Upon request	3	64	2560	-	-	-	-	-
55	4 6 8 10	CSG 90-2	10.67 9.78 8.97 7.83	3	65	2625	CSG 90-2 SFC	3.49 - 10.85 3.62 - 9.77 3.84 - 8.58 3.96 - 7.57	3	65	2685
75	4 6 8 10	CSG 120-2	13.10 13.07 12.15 10.58	3	66	2765	CSG 120-2 SFC	4.20 - 13.27 4.18 - 12.61 4.21 - 11.56 4.23 - 10.52	3	66	2825
90	4 6 8 10	CSG 130-2	- 13.03 13.00	3	68	2890	CSG 130-2 SFC	4.40 - 13.48 4.33 - 13.44 4.26 - 13.40 4.20 - 13.02	3	68	2950

¹⁾ Flow rate in accordance according to ISO 1217:2009, Annex C: absolute input pressure 1 bar(a); cooling and air input temperature 20 °C
²⁾ Sound pressure level according to ISO 2151 and the basic standard ISO 9614-2, tolerance: ± 3 dB(A), measured at maximum pressure and maximum speed
³⁾ Pressure dew point at inlet valve 1 bar(a); cooling and air inlet temperature 20 °C; relative humidity 60%, cooling water outlet temperature 30 °C

Specifications subject to change without notice

Equipment

Complete unit

Dry compression rotary screw compressor with 2-stage compression; condensate separator, condensate drain and fibre-free pulse dampers for both compression stages; oil tank ventilation with micro-filter, ready for operation, fully automatic, silenced.

Airend

2-stage, dry compression rotary screw airend with integrated gearing and collection tank for gear oil. Rotors feature durable coating. Both high and low pressure compression stages feature jacket cooling; high pressure stage with chromium steel rotors.

Drive:

Precision gearing as per AGMA Q13/DIN Class 5 with helical spur gears.

Drive motor

Premium efficiency IE4 drive motor, quality manufacture; IP 55 enclosure protection, PT-100 temperature sensor in windings; continuous measurement and monitoring of motor windings temperature.

Electrical components

Ventilated IP 54 control cabinet, automatic star-delta protection combination, overload relay, control transformer.

SIGMA CONTROL 2

Full-text display, 30 selectable languages; soft touch icon keys; 'traffic light' style LEDs to indicate operating status; fully automatic monitoring and control; Dual, Quadro and Dynamic control modes provided as standard; SD card slot for data logging and updates; RFID reader; web server; interfaces: Ethernet; optional communications modules for: Profibus DP, Modbus, Profinet and Devicenet.

Dynamic Control

The Dynamic Control feature calculates run-on times based on the motor winding temperature. This reduces idling times and cuts energy consumption. Additional control modes are stored in the SIGMA CONTROL 2 and can be called up as required.

Cooling

Optionally available with air- or water-cooling. Radial fan with separate drive motor. Exhaust air discharged upwards.

Air-cooled version:

High-pressure side: aluminium cooler with stainless steel tube pre-cooler. Low pressure side: aluminium cooler; aluminium cooler for cooler oil.

Water-cooled version:

Two shell and tube heat exchangers comprising coated steel jacket and pipes made from CuNi10Fe; one gear oil cooler.

Dependable oil reservoir venting

The microfilter in the oil reservoir venting system prevents intake of oil-laden air. This is another key detail to ensure that compressed air quality is reliably and efficiently maintained at all times.

- (1) Microfilter
- (2) Oil mist removal
- (3) Ejector
- (4) Return to gear oil reservoir

Options

KAESER hot air control

High temperature valve of quality manufacture; SIGMA CONTROL 2 regulates air temperature control downstream from the 2nd stage pulse damper. (Not available for packages with integrated rotary or refrigeration dryer.)

Bolt-down machine mounts

Machine mounts to bolt the machine to the floor.

Silenced inlet air opening (Air-cooled version)

Sound insulated connecting links upstream from heat exchangers.

Cooling air filter mats (Air-cooled version)

Cooling air filter mats in the compressor intake area; reduce contamination of heat exchanger surfaces and inlet air filters.

Heat recovery (Water-cooled version)

Heat recovery system can be optionally integrated; parallel switched tube-type heat exchanger; safety cooling system; safety pump, expansion tank, water control valves.

Auxiliary heat exchanger downstream from the 2nd stage air cooler (Water-cooled version)

Plate-type heat exchanger version; reduces outlet temperature for compressors with heat recovery.

Image: CSG 120-2 RD SFC with plate-type heat exchanger

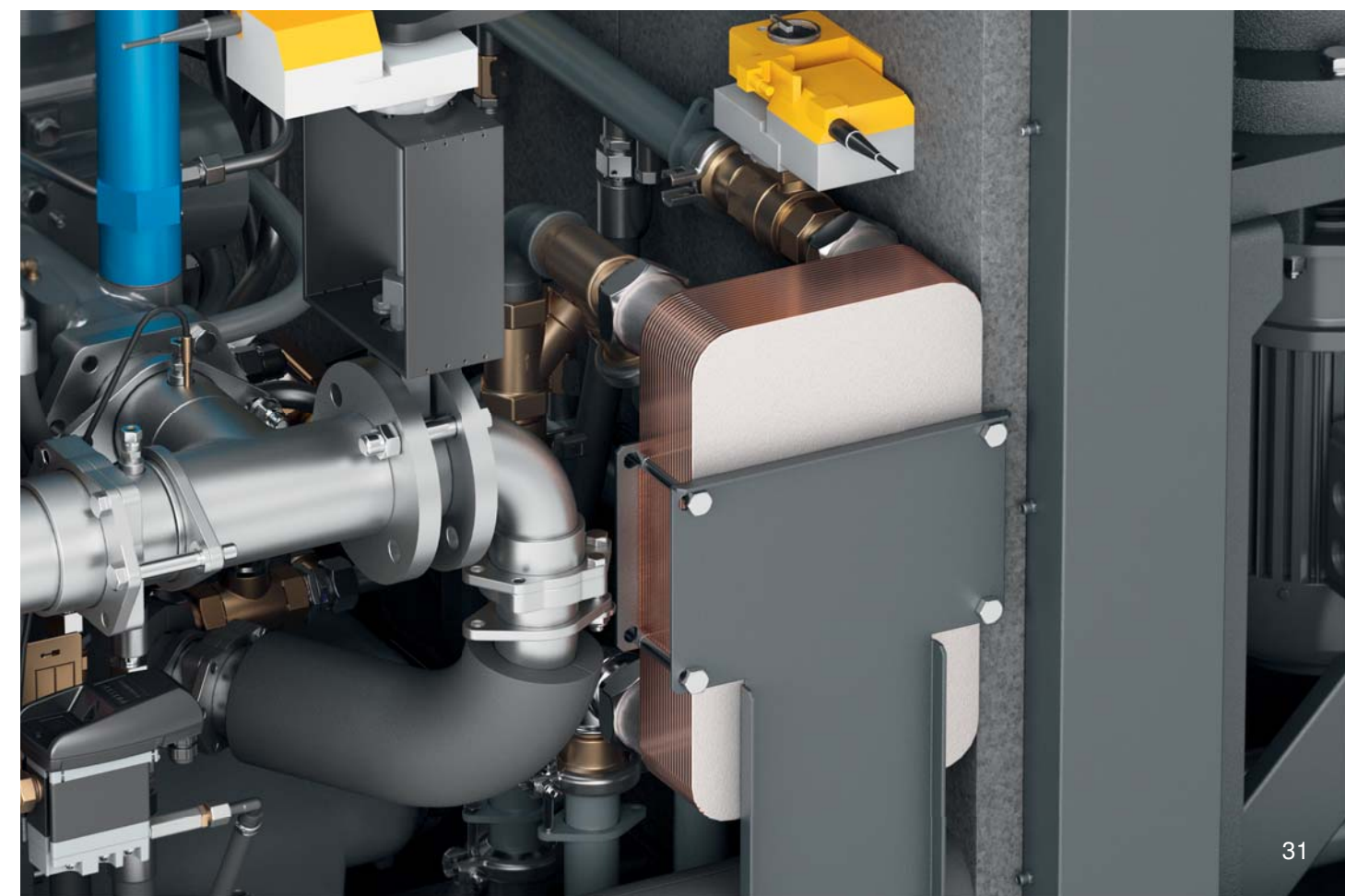
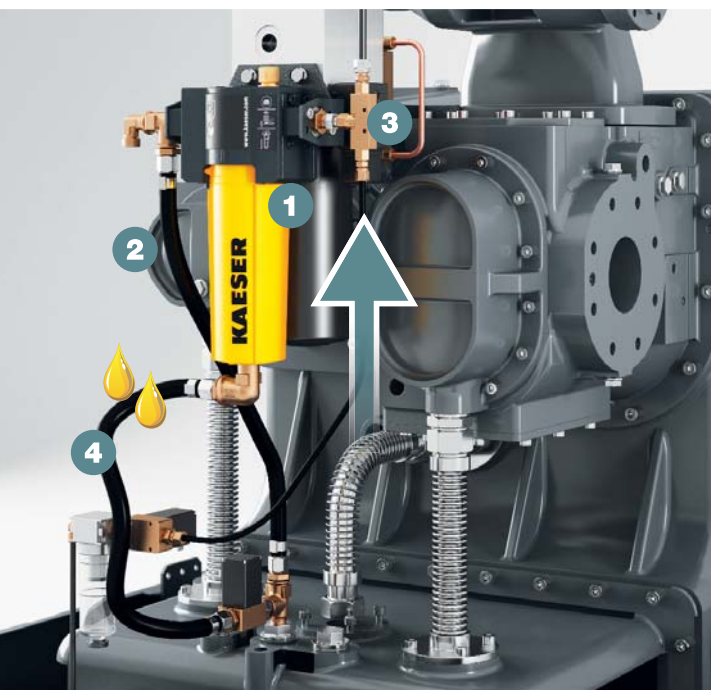

The world is our home

As one of the world's largest compressed air systems providers and compressor manufacturers, KAESER KOMPRESSOREN is represented throughout the world by a comprehensive network of branches, subsidiary companies and authorised partners.

With innovative products and services, KAESER KOMPRESSOREN's experienced consultants and engineers help customers to enhance their competitive edge by working in close partnership to develop progressive system concepts that continuously push the boundaries of performance and compressed air efficiency. Moreover, the decades of knowledge and expertise from this industry-leading system provider are made available to each and every customer via the KAESER group's global computer network.

These advantages, coupled with KAESER's worldwide service organisation, ensure that every product operates at the peak of its performance at all times and provides maximum availability.



KAESER KOMPRESSOREN SE

P.O. Box 2143 – 96410 Coburg – GERMANY – Tel +49 9561 640-0 – Fax +49 9561 640-130
e-mail: productinfo@kaeser.com – www.kaeser.com